

Installation Guide Template 3rd Party Installer



Installation Guide Template 3rd Party Installer

Site address:

Site contact:

Site Climate Intelligence™ dashboard link:

- User-
- Password-

Airkind Support Library link: <https://www.Airkind.ai/log-in/>

- User-
- Password-

[Important Site information to be placed here when assigning this document]

Add link to the site Climate Intelligence™ dashboard, with a unique user name and password for each installer

Grant and provide a unique user name and password for each installer for the Airkind support library.

Always use the following terminology:

OakGate > OakGate gateway unit	Airkind dashboard > Climate Intelligence™ dashboard
OakPTAC > OakPTAC controller	Window sensor > OakSense Window sensor
OakSocket > OakSocket controller	Door sensor > OakSense door sensor
OakRemote > OakRemote wireless thermostat	Occupancy sensor > OakSense PIR sensor
OakWall > OakWall wired thermostat	IAQ sensor > OakIAQ



In each room kit you will find: an **OakPTAC controller** with an **OakRemote wireless thermostat**, and an **OakSense door sensor** (if purchased).

There are 2 versions of the OakPTAC controller - OakPTAC controller V3 and OakPTAC controller V1.4. Each has slightly different wiring instructions, as described below.



OakGate gateway units will also be provided (one per every 40-50 rooms).



How the Airkind System Communicates:

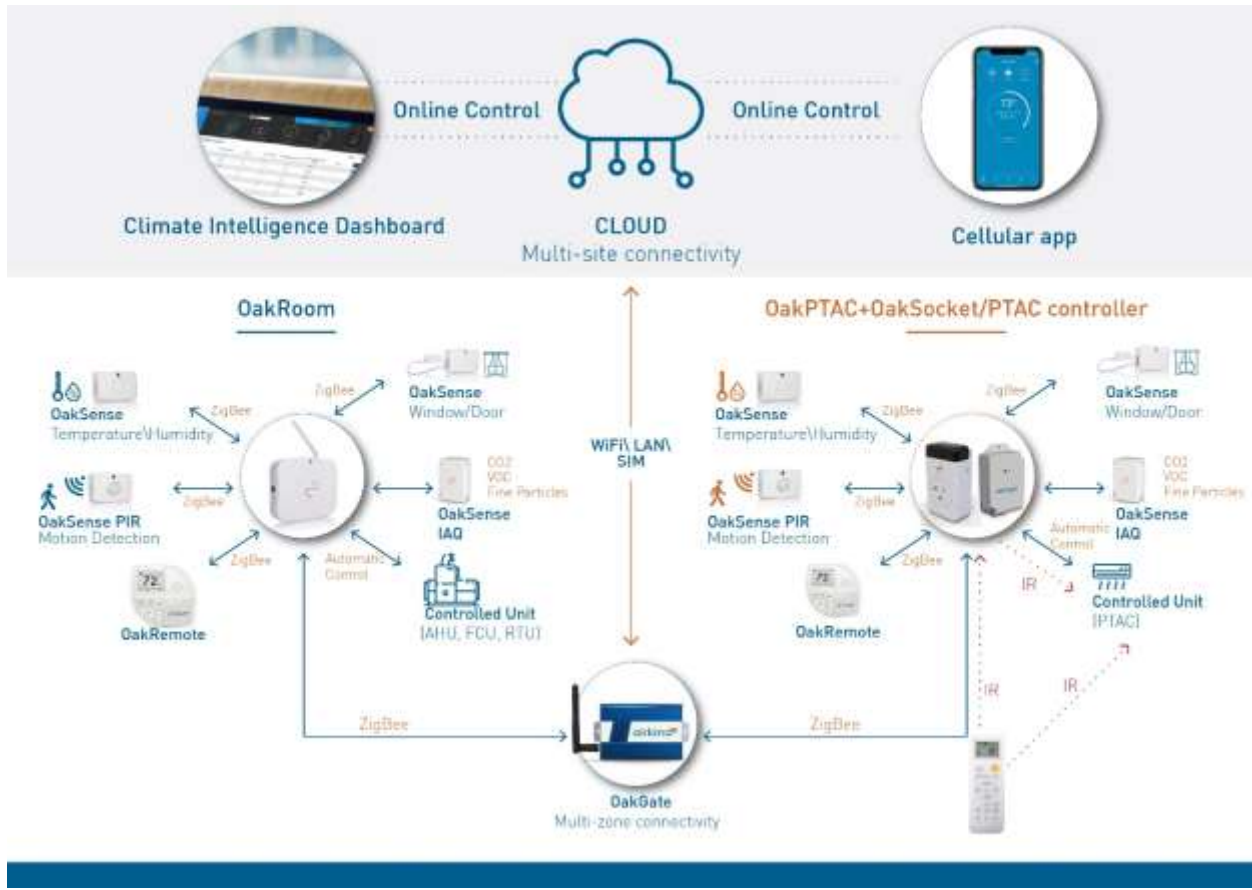

OakGate Gateway Unit Installation:

The OakGate is a gateway unit, connecting 40-50 controlled zones to the cloud. It connects to the zone controllers, and through them- it connects to the zone wireless sensors, and enables remote monitoring and control through the Climate Intelligence™ dashboard interface.



An OakGate gateway unit has 2 ways to be installed:

Installation option 1- POE splitter:

Step 1: Plug the power end into the power port, the ethernet into the OakGate gateway unit.

Step 2: Plug the ethernet cable into the POE splitter (as seen below.)

Step 3: Mount securely via velcro to sever rack or screw into wall.



Installation option 2- Separate power cord and ethernet:

Step 1: Plug in OakGate gateway to power.

Step 2: Plug in ethernet into OakGate gateway.

Step 3: Mount securely via velcro to sever rack or screw into wall.

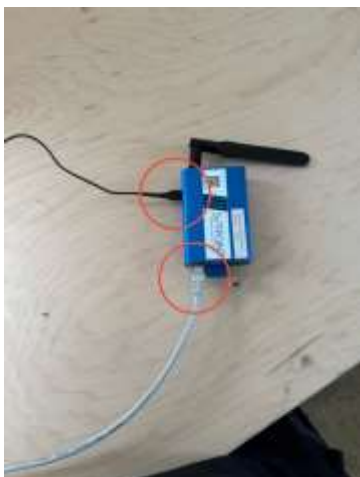

OakPTAC Controller Installation:

The OakPTAC controller is a wireless programmable room indoor climate controller that can connect to most HVAC units, immediately providing monitor, control and automation capabilities.

Prior to installation, test the HVAC unit in cool, heat, and fan modes to confirm it is operational

Installing OakPTAC Controller:

Step 1. Confirm unit ID number via QR code (bottom corner or inside unit)

Step 2. Match wiring harness to AC wiring

Step 3. Plug OakPTAC controller into the HVAC unit

Step 4. Confirm the Red light is on and the Blue light is blinking



The OakPTAC controller is supplied with connected wires in different colors. Each color is connected to a dedicated terminal.

OakPTAC v1.4 wiring



OakPTAC v3 wiring



Wiring color-coding per HVAC unit type and OakPTAC version in the table to follow.



Wiring color-code for connecting the OakPTAC controller to an HVAC Unit:

Conventional 1 stage cooling 1 stage heating

1 Stage Cool/1 Stage Heat	OakPTAC v1.4 Thermostat Wire Color - Code	OakPTAC V3
C/24V(N)	Black - Common	Black - Common
R/24V(L)	Red - Phase	Red - Phase
Y/COMP/AC	Yellow - AC	Yellow - Y1
O/B-Reversing Valve (Heat Pump)	-	-
GL/Fan Low	Green - Fan2	Green - Fan2
GH/Fan High	Blue - Fan1	Grey- Fan1
W - Electric heat	White-Heat	White - W1

Heat Pump 1 stage cooling 2 stage heat

1 Stage Cool/2 Stage Heat	OakPTAC v1.4 Thermostat	OakPTAC V3
C/24V(N)	Black - Common	Black - Common
R/24V(L)	Red - Phase	Red - Phase
Y/COMP/AC	Yellow - AC	Yellow - Y1
O/B-Reversing Valve (Heat Pump)	White - Heat	Blue- O/B (Heat Pump)
GL/Fan Low	-	Green - Fan2
GH/Fan High	Green- Fan 2	Grey- Fan1
W - Electric heat	Blue	White - W1

**Heat Pumps units with V1.4 OakPTACs will only have one fan speed.
Customers should determine whether to use high or low speed.**

OakRemote Wireless Thermostat:

The OakRemote wireless thermostat is a smart remote control, paired to its HVAC controller, supplying a full scale room profile. The OakRemote will measure room temperature, humidity, occupancy and more, allowing the user to control the HVAC unit via ZigBee wireless communication with its controller, as well as direct IR (infra-Red) signals.

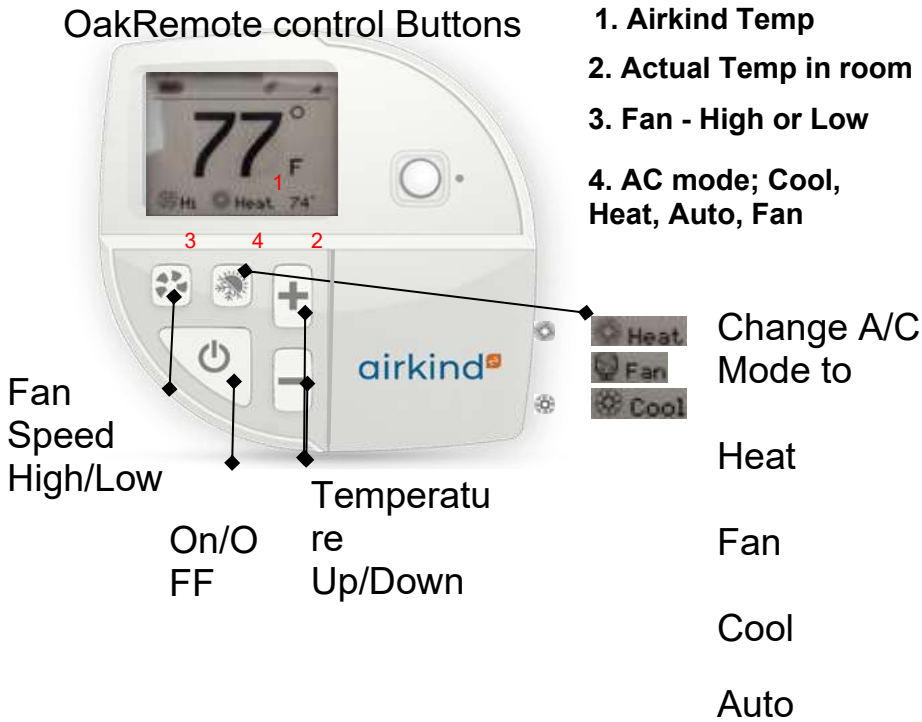

To mount the OakRemote wireless thermostat, remove the battery cover, locate the **2 holes** for the screws, mount level using the **built in level** and screw securely in place 48 inches above the ground with nothing blocking the Motion Sensor. **ADA Placement Requirements**

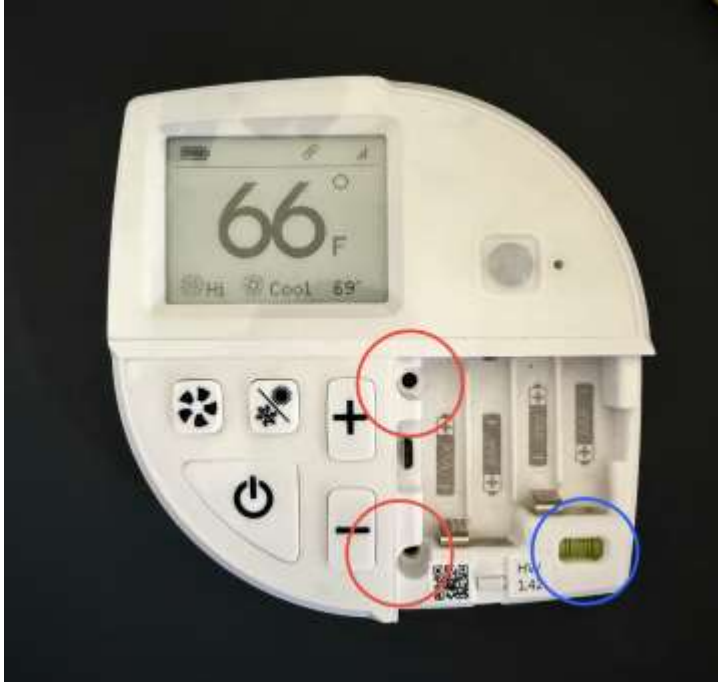

OakWall Wired Thermostat:

Certain sites will require different wiring to be determined at time of site survey



The OakWall wired thermostat is a sophisticated programmable thermostat and controller with wireless Zigbee communication ability. The OakWall wired thermostat is able to control a wide variety of Fan Coil units, as well as other A/C devices with standard 24VAC control interface such as room PTACs.

Installing OakWall wired thermostat:

1. **Prior to disconnecting wires- take a picture of the existing wiring into the old thermostat.**
2. Disassemble the old thermostat off the wall.
3. Following the wiring color code table below to match the wires to the correct terminal on the OakWall wired thermostat backplate (matching the old thermostat wiring).
4. Mount the backplate to the wall, then click the OakWall wired thermostat onto its backplate. **Once mounted- quickly power off the OakWall wired thermostat.**
5. Apply the correct HVAC unit configuration in the Climate Intelligence™ dashboard.

Oakwall 24	1 stage cooling / 1 stage heating	1 stage cooling / 2 stage heating
RC/RH-power	R/24v	R/24v

C-Common	C/24v	C/24v
Y-Compressor	Y/COMP/AC	Y/Comp/AC
W-Heat	W	O/B
G1	GL-Fan low	GL-Fan Low
G2	GH- Fan High	GH-Fan High
AUX	N/A	2nd Stage Heat

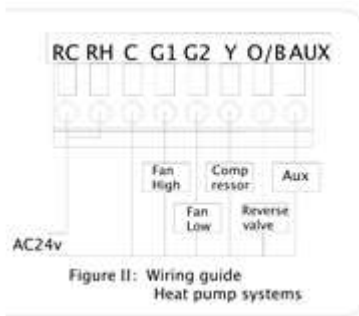

Connecting a Room to the wireless network:

1. Connect the Controller to the HVAC unit as per the wiring instructions.
2. Configure the 2 room identifiers on the Climate Intelligence™ *dashboard* as described below:
Room Name, Floor Number/Name and select the **HVAC unit type**.
3. Pair the OakRemote wireless thermostat with the OakPTAC controller, and mount the OakRemote wireless thermostat on the wall
4. Pair the OakSense Window/Door sensor to the OakPTAC controller, and mount the OakSense Window/Door sensor to the relevant window/door frame.

Pairing the Oak Remote wireless thermostat to the OakPTAC controller:

1. Place the OakRemote wireless thermostat on top of the *OakPTAC* controller.
2. Insert the 2 left AAA batteries and the OakRemote wireless thermostat will automatically pair to the closest OakPTAC controller

Pairing the OakSense Window/Door sensor to the OakPTAC controller:

1. Place the OakSense Window/Door on the *OakPTAC controller*
2. Insert the 2 AAAA batteries and the OakSense Window/Door sensor will automatically pair to the closest OakPtac controller.

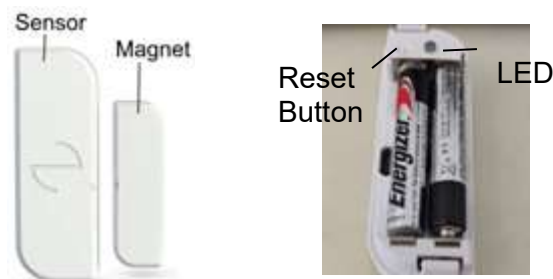

Uploading a Room to the dashboard:

The Climate Intelligence™ Dashboard is a secure internal interface for multiple-level users, acting as an interface to the HVAC system installed on-site. Through the Climate Intelligence™ dashboard, the customer can monitor, operate and customize the HVAC system remotely.

To add a new OakPTAC controller to the Climate Intelligence™ dashboard, please follow the next steps:

1. Go to the Climate intelligence™ platform using this link: **<insert Dashboard link>**
2. The new OakPTAC controller will be found in the “Not Assigned” floor.



3. Locate the OakPTAC controller's ID number looking at its **ID sticker**.
4. Press that ID number under the Not Assigned Floor to open the Room Dialogue window for setup.

- Name the room and assign it to the relevant floor
- Press on the ac type to choose: PTAC
- Choose the correct PTAC unit
- Press Apply

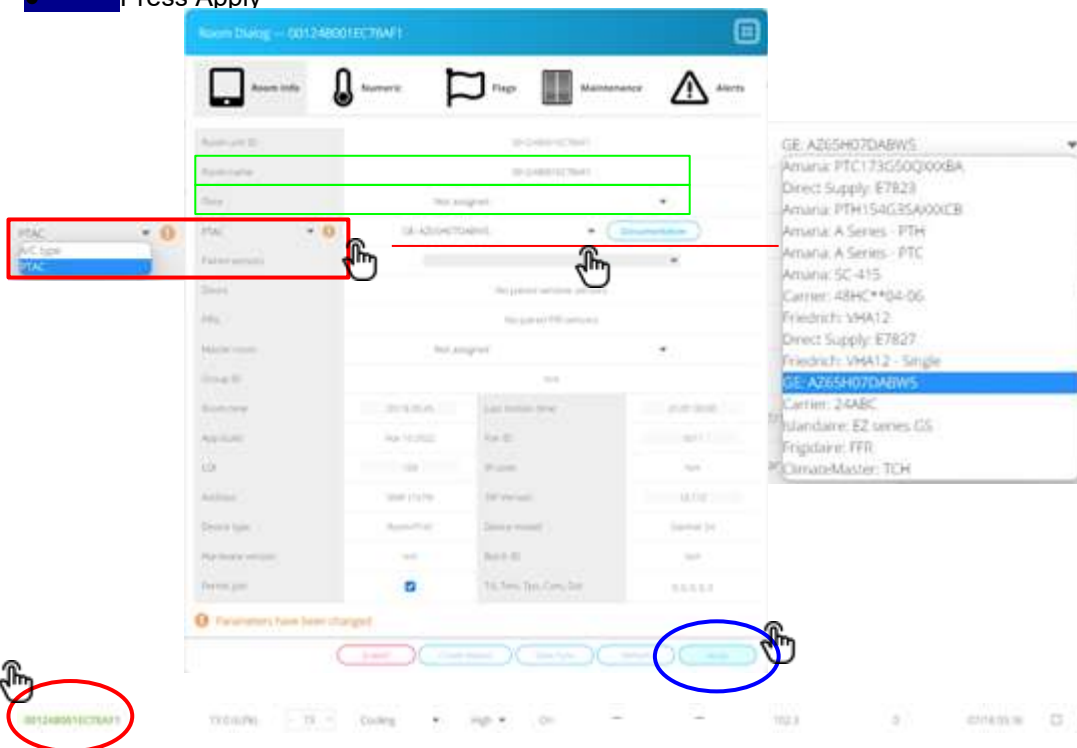

Post-installation Testing:

1. Pair APIPT sensor to OakPTAC controller
2. Attach sensor to the HVAC vent
3. Run test
4. Confirm report is ready



How to Run the Auto Post Install Ptac Test (APIPT Test):

Room dialog box → Maintenance tab → "Operation Test" line:

1. If test never passed for this controller: Page says: "NEVER TESTED", Press Button: "Run test"
2. If test is running: Page says: "TEST RUNNING, Started: <datetime started>", Button "Abort test"
3. If test not running and passed: Page says: "TEST PASSED, Finished: <date/time finished>, Report <download link>", Button "Run again"
4. If test not running and failed: Page Says: "<error description(see below)> Finished: <date/time finished>, Report <download link>", Button "Run again"



How to Test a Room without an APIPT Sensor:

1. On the OakRemote wireless thermostat, set the unit to fan and Airkind to lower than temperature inside. Confirm the fan is working. Test low and high fan speeds
2. After Fanning swap to cooling and adjust the Airkind to be lower than 5 degrees than what is in the room. Wait for the fan then within 5 to 10 minutes the compressor should come on, test with a temperature gun. Adjust the Airkind to the temperature in the room to confirm the unit turns off
3. After cooling test heating, adjust the Airkind to 5 degrees above the room temperature, wait 5 to ten minutes and confirm that heat is coming out with a temperature gun. (If a unit has a 2nd stage of heating, confirm the 2nd stage has engaged) Once heat is confirmed, lower the Airkind to the rooms temperature to confirm the unit turns off

